

# Lo-Carbon MVDC & SENTINEL MULTIVENT RANGE

## VENTILATION SYSTEMS

### Quick Start Guide

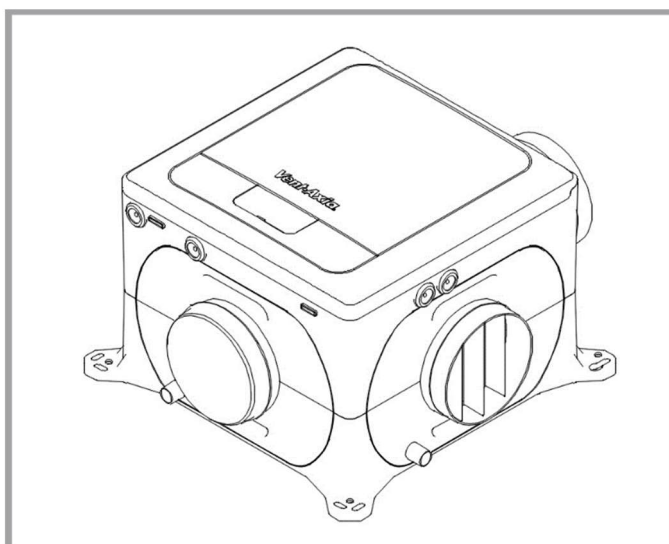

#### Stock Ref. N°

MVDC-MS	437634C
MVDC-MSH	443298B
SMV-H	445655B
SMV-HX	495360
SMV-HX CO <sup>2</sup>	495361
SMV PLUS-H	407849A
SMV PLUS-HX	495362
SMV PLUS-HX CO <sup>2</sup>	495363
SMV PLUS-H (Ventair)	496186

X-Units have wireless controls and Bluetooth capability.

220-240V~50Hz

# Vent-Axia®

Full instructions and feature explanations are available online by scanning the QR code or by visiting:  
<https://www.vent-axia.com/range/centralised-mechanical-extract-ventilation-mev>



CE  
IPX2



ORIGINAL ENGLISH QUICK START GUIDE

DOWNLOAD THE APP HERE:





PLEASE KEEP THIS QUICKSTART GUIDE AND READ IN CONJUNCTION WITH THE ILLUSTRATIONS.

## Installation and Wiring Instructions for the Multivent Multi-Speed Extract Fans.



### IMPORTANT:

### READ THESE INSTRUCTIONS BEFORE COMMENCING THE INSTALLATION

- Do not install this product in areas where the following may be present or occur:
  - Excessive oil or a grease laden atmosphere.
  - Corrosive or flammable gases, liquids or vapours.
  - Subject to direct water spray from hoses.
  - Ambient temperatures higher than 40°C and lower than -20°C.
  - Possible obstructions that may hinder access to or removal of the unit.
- All wiring must be in accordance with the current IEE wiring regulations BS7671, or appropriate standards of your country. Installation should be inspected and tested by a suitably qualified person after completion.
- Ensure the mains supply (voltage, frequency and phase) complies with the rating label.
- The unit should be provided with a local double pole fused spur fitted with a 3A fuse having a contact separation of at least 3mm.
- Units showing  on the rating label incorporate an earth connection for functional purposes only.
- Units showing  on the rating label have a Protective Earth.
- Precautions must be taken to avoid the backflow of gases into the building from the open flue of gas or other fuel-burning appliances.
- This appliance is not intended for use by persons (including children) with reduced physical, sensory or mental capabilities, or lack of experience and knowledge, unless they have been given supervision or instruction concerning use of the appliance by a person responsible for their safety.
- Young children should be supervised to ensure that they do not play with the appliance.
- Cleaning and user maintenance shall not be made by children
- The installer is responsible for the installation and electrical connection of the unit on site. It is the responsibility of the installer to ensure that the equipment is safely and securely installed and left only when mechanically and electrically safe.
- All regulations and requirements must be strictly followed to prevent hazards to life and property, both during and after installation, and during any subsequent servicing and maintenance.
- Certain applications may require the installation of sound attenuation to achieve the sound levels required.
- The unit must not be connected directly to a tumble drier.
- The exhaust grille should be located at least 600mm away from any flue outlet.
- This product and associated duct installation should be carried out in accordance with the Domestic Ventilation Compliance Guide.

### **Models that support Radio and Bluetooth communication the below applies**

- Bluetooth variants contain FCC ID: S9NSPBTLERF
- Bluetooth LE: -12dBm EIRP (63µW), nominal 2450MHz.
- Bluetooth v4.1 compliant
- Bluetooth and radio variants obtained RED certificate: No. 0051-RED-0011 REV. 0
- Zirconia Wireless: -14dBm EIRP nominal 868MHz.
- The manufacturer hereby assure that this type of Bluetooth radio and 868MHz radio equipment complies with RED Directive 2014/53 / EU

The full text of the EU Declaration of Conformity can be found at the following URL:

<https://www.vent-axia.com/range/centralised-mechanical-extract-ventilation-mev>

## **INSTALLATION**

Position the unit, taking into consideration the position of the rooms to be ventilated, the exhaust position and the electrical services. Ensure there is adequate access for installation and maintenance.

If the unit is sited in the heated void of the dwelling a condensate drain should not be necessary. When sited in a cold loft, consideration should be given to fitment of a condensate drain. Alternatively, the unit and ducting can be externally insulated to minimize condensation within the units housing.

To reduce the system resistance in your duct system, and therefore lower the speed, power consumption and noise of the fan, follow these guidelines:

- 1.1. Keep the length of duct runs to a minimum, particularly the exhaust duct run.
- 1.2. If you need to use flexible ducting, make sure that it is fully extended and not crushed, sagging or torn.
- 1.3. Try to minimize the use of diffusers/valves by having similar length duct runs to the inlets.
- 1.4. The bend radius (measured to the inside of the bend) should be at least 1x the duct diameter.
- 1.5. Avoid having any bends, filters or other obstructions within 250mm of the fan inlets and outlet.

Securely mount the unit through the mounting holes on the casing using appropriate fixings (not supplied) for the mounting substrate. Fixings to be capable of securing 4x the weight of the unit. Unit weight: 4.1kg. Anti-vibration mounts, acoustic mats or rubber bushes can also be used.

**Mounting point dimensions and installation example shown below:**

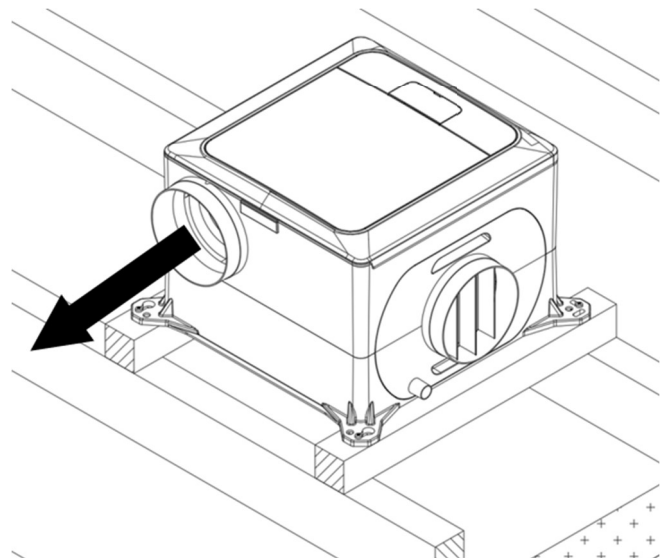
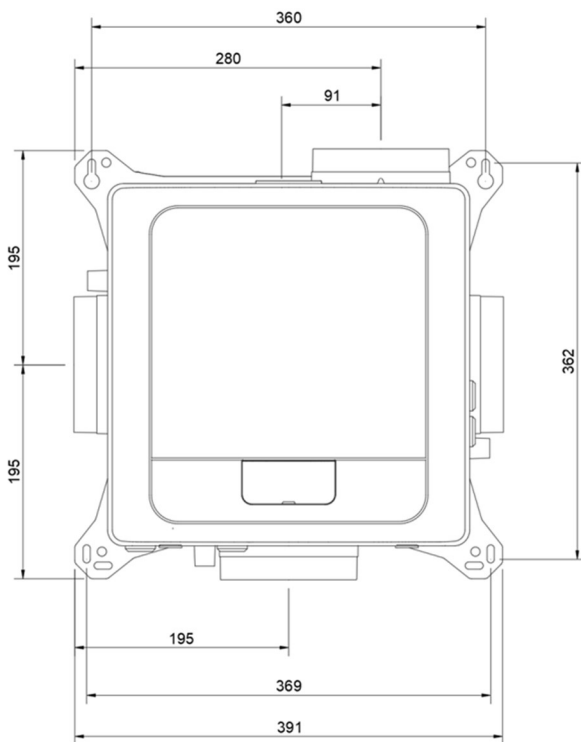

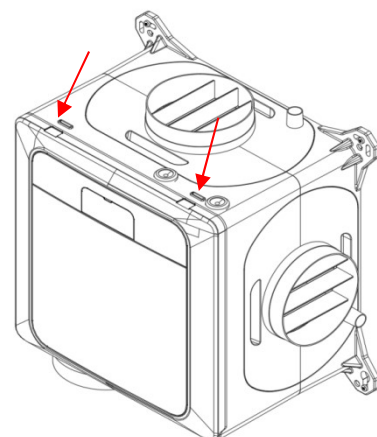

**To maintain the IPx2 rating of the unit, the unit must not be mounted with the cover removal slots facing upwards, or at an angle where they are visible from above. All other orientations are acceptable.**



## WIRING



**WARNING:**  
**THE UNIT AND ANCILLARY CONTROL EQUIPMENT MUST BE ISOLATED FROM THE POWER SUPPLY DURING THE INSTALLATION / OR MAINTENANCE. THIS UNIT MUST BE EARTHED.**

- To remove the cover, use a coin or similar; depress the retaining tabs via the slots in the side of the unit.
- With the power off, connect a suitable mains power cable from a switched, fused spur to the screw terminal block. Use the cable clamps and clip provided to secure the lead.
- Two mains voltage Live Switched (LS1 and LS2) connections are provided and can be used to trigger a change in speed. Common inputs would be from a bathroom lighting circuit. When commissioning the unit, a delay on timer and an overrun timer can be selected and adjusted in the software using the buttons and screen. See Commissioning section on page 5 of this document for details.
- The switched live output (230Vac) from any other switch or controller, (such as a simple latching pullcord or push-button switch, humidistat or PIR detector) can be connected to the LS terminal instead of connecting to a lighting circuit.
- Important: Use 4-core, low voltage, twisted pair, telecoms type cable for accessories (Vent-Axia part number 459931). Accessories are connected via the IO (Input Output) PCB; see the Low Voltage Connections diagram in the Main fitting and wiring guide, downloadable on the website.
- There are no delay-on or overrun timers with the volt-free connection as the controller should determine when the fan is running at Boost or Normal speeds. Use the LS connection described above if you want a timer.
- Units showing  on the rating label incorporate an earth connection for functional purposes only. Units showing  on the rating label have a Protective Earth.



### **A: Main power connections**

The LS1, LS2 and NS terminals are electrically isolated.

Note: Neutral link between 2 & 6 should be removed if different RCD protection circuits are used for mains power & Live Switch connections.

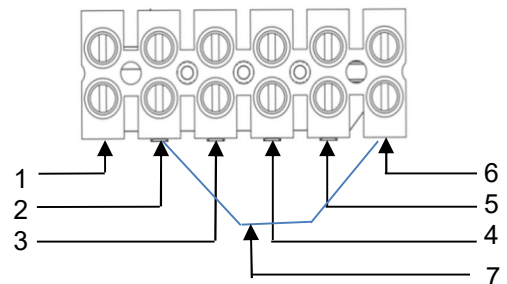
Note: Ensure all live & neutral are isolated before servicing.



<u>Connection</u>	<u>Description</u>
1	L Live (220-240Vac)
2	N Neutral
3	 Functional Earth
	 Protective Earth
4	LS1 Live Switched 1, (220-240Vac), isolated
5	LS2 Live Switched 2 (220-240Vac), isolated
6	NS Neutral Switched, isolated
7	N + NS Link Wire (Blue)

## COMMISSIONING

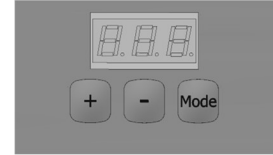

1. Commissioning and configuration on all products is supported by the 3-digit user interface and associated push buttons:
2. When powered on, the unit will display the firmware revision number, after a few seconds the unit will display the first option in the User Parameters (**see table on next page**).
3. The display will enter standby mode after defined timeout (default 10min) or user selects “END” option in menu, press the Mode button to turn the display back on.
4. Changes to the settings can be made via the **+** and **-** buttons, the Mode button will accept changes and move onto the next menu option.
5. When setting the speeds, there is an internal logic: low<Normal<Boost<Purge. I.e., Boost is always higher than Normal.
6. The actions for each of the Live Switched (LS), inputs are selectable. The setting for delays and over run timers are applicable to all inputs.
7. If the unit being commissioned is not fitted with the relevant hardware, the associated menu options will not be available.

### **Pairing wired and wireless accessories (If supported by model)**

To enter pairing mode, with the display illuminated, press and hold the **Mode** button until LED illuminates **solid White**, release the **Mode** button and the LED will **flash White**, indicating pairing mode is active along with the paired device count on the display. Pairing mode will time out after 5 minutes.

To activate pairing on the accessory, refer to the device manual.

### **Control via Bluetooth**

Selected units can be controlled via the Bluetooth linked App.

With the display on, press and hold the Mode button until the Blue LED illuminates, release the button and the LED will flash signifying that pairing mode is enabled.

Use the QR codes on the coversheet to download the App.

## SERVICING & MAINTENANCE



**WARNING: THE FAN AND ANCILLARY CONTROL EQUIPMENT MUST BE ISOLATED FROM THE POWER SUPPLY DURING MAINTENANCE.**

1. At intervals appropriate to the installation, the fan should be inspected and cleaned to ensure there is no significant buildup of dirt or other deposits.
2. To inspect the inside of the product, isolate the power, use a coin or similar to depress the cover retention clips.
3. Remove the cover, remove the scroll assembly by unscrewing the two screws and unclipping the clips in the two corners and pulling away. If necessary, vacuum the inside of the unit.
4. The fan has sealed for life bearings, which do not require lubrication. Expected service life is at least 45,000 hours continuous running.
5. Check all fixings are tight and secure

## User Configurable Parameters:

Display text	Function	Selections	Default
Lxx	Low speed	1 to 97% motor speed	10%
nxx	Normal speed	2 to 98% motor speed	25%
bxx	Boost speed	3 to 99% motor speed	35%
Pxx	Purge Speed	4 to 100% motor speed	50%
LS1	Live switch 1	Low, Boost or Purge speed	Low
LS2	Live switch 2	Low, Boost or Purge speed	Boost
LS3	Live switch 1&2	Low, Boost or Purge speed	Purge
c-n	Comfort mode	Comfort mode - yes or no	No
d-n	Delay On	Delay on - yes or no	No
dxx	Delay On time	Delay to boost duration 1 to 60 minutes	10m
o-n	Overrun	Overrun - yes or no	No
oxx	Overrun time	Overrun duration 1 to 60 minutes	10m
r-y	Humidity – Rapid Rise	Rapid rise - yes or no	No
A-n	Humidity – Ambient Response	Ambient response - yes or no	No
hxx	Humidity threshold	Ambient response threshold 40 to 90% RH	70%
C2b	CO <sub>2</sub> threshold boost	Boost threshold 650 – 4950 PPM in increments of 50	100
C2P	CO <sub>2</sub> threshold purge	Purge threshold 700– 5000 PPM in increments of 50	120
A1LA	Analogue 1 - low action	Low, Normal, Boost or Purge speed	Low
A1HA	Analogue 1 - high action	Low, Normal, Boost or Purge speed	Boost
A1tL	Analogue 1 - low threshold	Analogue Input Threshold Low 1 - 99	15
A1tH	Analogue 1 - high threshold	Analogue Input Threshold High 1 - 99	75
A2LA	Analogue 2 - low action	Low, Normal, Boost or Purge speeds	Low
A2HA	Analogue 2 - high action	Low, Normal, Boost or Purge speeds	Boost
A2tL	Analogue 2 - low threshold	Analogue Input Threshold Low 1 - 99	15
A2tH	Analogue 2 - high threshold	Analogue Input Threshold High 1 - 99	75
D1	Digital input 1 Action	Low, Boost or Purge speeds	Low
D2	Digital input 2 Action	Low, Boost or Purge speeds	Boost
unl	Unlock code	Turn on/off the menu lock	- - -
PIIn	Display Pin	3 characters A to 9	LoC
dtxx	Display time	Adjust how long the display is illuminated	10m
rot	Rotate display	Invert the display	rot
hu	Humidity	Show the current internal humidity	%
tu	temperature	Show the current internal temperature	°C
CO <sub>2</sub>	CO <sub>2</sub>	Show the current CO <sub>2</sub> level	PPM
rEf	Calibration reference value	40 to 200	40 (400ppm)
cAL	Calibration Mode	Y to enable	n
end	end	End of menu (loop to start)	

If the unit being commissioned is not fitted with the relevant hardware, the associated menu options will not be available.

## Product Fiche

Name:	Vent-Axia							
Model ID (Stock Ref.) :	437634C	443298B	445655B	495360	495361	407849A 496186	495362	495363
SEC Class	B		B			B		
SEC Value ('Average')	-27.2		-27			-26.9		
SEC Value ('Warm')	-11.7		-11.5			-11.4		
SEC Value ('Cold')	-54.3		-54.1			-54.0		
Label Required? (Yes/No=Out of scope)	Yes							
Declared as: RVU or NRVU/UVU or BVU	RVU/UVU							
Speed Drive	Multi Speed							
Type HRS (Recuperative, Regenerative, None)	None							
Thermal Eff: [ (%), NA(if none)]	N/A							
Max. Flow Rate (m3/h)	338.8		400			505.1		
Max. Power Input (W): (@Max.Flow Rate)	43		52			85		
LWA: Sound Power Level dB)	46.4		50.7			52.2		
Ref. Flow Rate (m3/s)	0.066		0.078			0.098		
Ref. Pressure Diff. (Pa)	201		203			206		
SPI [W/(m3/h)]	0.07		0.08			0.09		
Control Factor & Control Typology: (CTRL/ Typology)								
Control Factor; CTRL	0.65							
Control Typology	Local Demand Control							
Declared: -Max Internal & External Leakage Rates(%) for BVUs or carry over (for regenerative heat exchangers only), Ext. Leakage Rates (%) for Ducted UVUs;	<5% Internal, <5% External							
Mixing Rate of Non-Ducted BVUs not intended to be equipped with one duct connection on either supply or extract air side;	N/A							
Position and description of visual filter warning for RVUs intended for use with filters, including text pointing out the importance of regular filter changes for performance and energy efficiency of the unit	N/A							
For UVUs (Instructions Install Regulated Supply/Extract Grilles Façade)	In F&W							
Internet Address (for Disassembly Instructions)	www.vent-axia.com							
Sensitivity p. Variation@+20/-20 Pa: (for Non-Ducted VUs)	N/A							
Air Tightness-ID/OD-(m3/h) (for Non-Ducted VUs)	N/A							
Annual Electricity Consumption: AEC (kWh/a)	0.4		0.5			0.6		
Annual Heating Saved: AHS (kWh/a)								
AHS: Average	28.3		28.3			28.3		
AHS: Warm	12.8		12.8			12.8		
AHS: Cold	55.4		55.4			55.4		

## Disposal

This product should not be disposed of with household waste. Please recycle where facilities exist. Check with your local authority for recycling advice.



## The **Vent-Axia** Guarantee

Applicable only to products installed and used in the United Kingdom. For details of guarantee outside the United Kingdom contact your local supplier.

Vent-Axia guarantees its products for two years from date of purchase against faulty material or workmanship. In the event of any part being found to be defective, the product will be repaired, or at the Company's option replaced, without charge, provided that the product:-

- Has been installed and used in accordance with the instructions given with each unit.
- Has not been connected to an unsuitable electricity supply. (The correct electricity supply voltage is shown on the product rating label attached to the unit).
- Has not been subjected to misuse, neglect or damage.
- Has not been modified or repaired by any person not authorised by the company.

### IF CLAIMING UNDER TERMS OF GUARANTEE

Please return the complete product, carriage paid to your original supplier or nearest Vent-Axia Centre, by post or personal visit. Please ensure that it is adequately packed and accompanied by a letter clearly marked "Guarantee Claim" stating the nature of the fault and providing evidence of date and source of purchase.

The guarantee is offered to you as an extra benefit, and does not affect your legal rights

## **Vent-Axia**

Head Office: Fleming Way, Crawley, West Sussex, RH10 9YX. Tel: 01293 526062 Fax: 01293 551188  
UK NATIONAL CALL CENTRE, **Newton Road, Crawley, West Sussex, RH10 9JA**

SALES ENQUIRIES: Tel: 0344 8560590 Fax: 01293 565169  
TECHNICAL SUPPORT: Tel: 0344 8560594 Fax: 01293 532814  
Web: [www.vent-axia.com](http://www.vent-axia.com) Email: [info@vent-axia.com](mailto:info@vent-axia.com)

### **Ventair Australia**

Tel: +61 3 9775 0556  
Fax: +61 39775 0775  
Email: [info@ventair.com.au](mailto:info@ventair.com.au)

4 Capital Place, Carrum Downs, VIC 3201, Australia

As part of the policy of continuous product improvement Vent-Axia reserves the right to alter specifications without notice.

EU Authorised Representative: Vent-Axia Bedrijvenweg 17 7442 CX Nijverdal Nederland [authorisedrep@vent-axia.nl](mailto:authorisedrep@vent-axia.nl)